



*Aprisa* **SR**



# Product Description

August 2013  
Version 1.6.0



## Copyright

Copyright © 2013 4RF Limited. All rights reserved.

This document is protected by copyright belonging to 4RF Limited and may not be reproduced or republished in whole or part in any form without the prior written permission of 4RF Limited.

## Trademarks

Aprisa and the 4RF logo are trademarks of 4RF Limited.

Windows is a registered trademark of Microsoft Corporation in the United States and other countries. Java and all Java-related trademarks are trademarks or registered trademarks of Sun Microsystems, Inc. in the United States and other countries. All other marks are the property of their respective owners.

## Disclaimer

Although every precaution has been taken preparing this information, 4RF Limited assumes no liability for errors and omissions, or any damages resulting from use of this information. This document or the equipment may change, without notice, in the interests of improving the product.

## RoHS and WEEE compliance

The Aprisa SR is fully compliant with the European Commission's RoHS (Restriction of Certain Hazardous Substances in Electrical and Electronic Equipment) and WEEE (Waste Electrical and Electronic Equipment) environmental directives.

### Restriction of hazardous substances (RoHS)

The RoHS Directive prohibits the sale in the European Union of electronic equipment containing these hazardous substances: lead, cadmium, mercury, hexavalent chromium, polybrominated biphenyls (PBBs), and polybrominated diphenyl ethers (PBDEs).

4RF has worked with its component suppliers to ensure compliance with the RoHS Directive which came into effect on the 1<sup>st</sup> July 2006.

### End-of-life recycling programme (WEEE)

The WEEE Directive concerns the recovery, reuse, and recycling of electronic and electrical equipment. Under the Directive, used equipment must be marked, collected separately, and disposed of properly.

4RF has instigated a programme to manage the reuse, recycling, and recovery of waste in an environmentally safe manner using processes that comply with the WEEE Directive (EU Waste Electrical and Electronic Equipment 2002/96/EC).

4RF invites questions from customers and partners on its environmental programmes and compliance with the European Commission's Directives (sales@4RF.com).

## Compliance General

The Aprisa SR digital radio predominantly operates within frequency bands that require a site license be issued by the radio regulatory authority with jurisdiction over the territory in which the equipment is being operated.

It is the responsibility of the user, before operating the equipment, to ensure that where required the appropriate license has been granted and all conditions attendant to that license have been met.

Changes or modifications not approved by the party responsible for compliance could void the user's authority to operate the equipment.

Equipment authorizations sought by 4RF are based on the Aprisa SR radio equipment being installed at a fixed restricted access location and operated in point-to-multipoint or point-to-point mode within the environmental profile defined by EN 300 019, Class 3.4. Operation outside these criteria may invalidate the authorizations and / or license conditions.

The term 'Radio' with reference to the Aprisa SR User Manual, is a generic term for one end station of a point-to-multipoint Aprisa SR network and does not confer any rights to connect to any public network or to operate the equipment within any territory.

## Compliance European Telecommunications Standards Institute

The Aprisa SR radio is designed to comply with the European Telecommunications Standards Institute (ETSI) specifications as follows:

	12.5 kHz Channel	25 kHz Channel
Radio performance	EN 300 113-2	EN 302 561
EMC	EN 301 489 Parts 1 & 5	
Environmental	EN 300 019, Class 3.4	
Safety	EN 60950-1:2006	

Frequency band	Channel size	Power input	Notified body
136-174 MHz	12.5 kHz	12 VDC	
400-470 MHz	12.5 kHz, 25 kHz	12 VDC	

## Compliance Federal Communications Commission

The Aprisa SR radio is designed to comply with the Federal Communications Commission (FCC) specifications as follows:

Radio performance / EMC	47CFR part 90 Private Land Mobile Radio Services 47CFR part 15 Radio Frequency Devices
Safety	EN 60950-1:2006

Frequency band limits	Channel size	Power input	Authorization	FCC ID
406.1 to 454.0 MHz 456.0 to 470.0 MHz	12.5 kHz	12 VDC	Part 90 Certification	UIPSRN0400012A

NOTE: This equipment has been tested and found to comply with the limits for a Class A digital device, pursuant to part 15 of the FCC Rules. These limits are designed to provide reasonable protection against harmful interference when the equipment is operated in a commercial environment. This equipment generates, uses, and can radiate radio frequency energy and, if not installed and used in accordance with the instruction manual, may cause harmful interference to radio communications. Operation of this equipment in a residential area is likely to cause harmful interference in which case the user will be required to correct the interference at his own expense.

## Compliance Industry Canada

The Aprisa SR radio is designed to comply with Industry Canada (IC) specifications as follows:

Radio performance	RSS-GEN RSS-119
EMC	This Class A digital apparatus complies with Canadian standard ICES-003. Cet appareil numérique de la classe A est conforme à la norme NMB-003 du Canada.
Safety	EN 60950-1:2006

Frequency band limits	Channel size	Power input	Authorization	IC ID
406.1 to 430.0 MHz 450.0 to 470.0 MHz	12.5 kHz, 25 kHz	12 VDC	RSS-119	6772A-SRN400

## RF Exposure Warning



### WARNING:

The installer and / or user of Aprisa SR radios shall ensure that a separation distance as given in the following table is maintained between the main axis of the terminal's antenna and the body of the user or nearby persons.

Minimum separation distances given are based on the maximum values of the following methodologies:

1. Maximum Permissible Exposure non-occupational limit (B or general public) of 47 CFR 1.1310 and the methodology of FCC's OST/OET Bulletin number 65.
2. Reference levels as given in Annex III, European Directive on the limitation of exposure of the general public to electromagnetic fields (0 Hz to 300 GHz) (1999/519/EC). These distances will ensure indirect compliance with the requirements of EN 50385:2002.

Frequency (MHz)	Maximum Power (dBm)	Maximum Antenna Gain (dBi)	Minimum Separation Distance (m)
136	+ 37	15	2.5
174	+ 37	15	2.5
330	+ 37	15	2.5
400	+ 37	15	2.5
470	+ 37	15	2.3

# Contents

<b>1. Introduction.....</b>	<b>9</b>
The 4RF Aprisa SR Radio.....	9
Product Overview .....	10
Network Coverage and Capacity .....	10
Remote Messaging.....	10
Repeater Messaging .....	11
Product Features .....	12
Functions .....	12
Performance .....	12
Usability .....	12
Architecture.....	13
Security .....	13
Interfaces.....	14
Antenna Interface .....	14
Ethernet Interface .....	14
RS-232 Interface.....	14
USB Interfaces .....	14
Alarms.....	14
Mounting.....	15
DIN Rail Mounting .....	15
Rack Shelf Mounting .....	16
Wall Mounting.....	17
Product Options .....	18
Dual Antenna Port.....	18
Protected Station.....	19
Operation.....	19
Data Driven Protected Station.....	20
Operation.....	20
Installation .....	22
Duplexer Kits.....	24
UHF Duplexer Kits .....	24
VHF Duplexer Kits .....	24

<b>2. Specifications</b>	<b>25</b>
RF Specifications	25
Frequency Bands	25
Channel Sizes	25
Transmitter	25
Receiver	26
Modem	26
Data Payload Security	26
Interface Specifications	27
Ethernet Interface	27
RS-232 Asynchronous Interface	27
Hardware Alarms Interface	28
Protection Switch Specifications	28
Power Specifications	29
Power Supply	29
Power Consumption	29
Power Dissipation	30
General Specifications	31
Environmental	31
Mechanical	31
Compliance	31
<b>3. Management</b>	<b>33</b>
SuperVisor	33
Viewing the Aprisa SR Terminal Summary	34
Configuring the Aprisa SR Terminal Device	34
Configuring the Aprisa SR Radio Channel Setup	35
Configuring the Aprisa SR Radio Setup	35
Command Line Interface	36
LED Display Panel	37
Normal Operation	37
Single Radio Software Upgrade	38
Network Software Upgrade	38
Test Mode	38
<b>4. Applications</b>	<b>39</b>
Basic point-to-multipoint application	39
Advanced point-to-multipoint application with repeater	40
Multi-interface point-to-multipoint application	41



<b>5. Architecture .....</b>	<b>42</b>
Product Description .....	42
Physical Layer.....	42
Data Link Layer / MAC layer .....	42
Channel Access .....	42
Hop by Hop Transmission.....	43
Network Layer .....	44
Packet Routing.....	44
Security .....	45
Product Architecture .....	46
Radio Block Diagram .....	47
Modem Block Diagram .....	47
<b>6. Contact Us .....</b>	<b>48</b>



# 1. Introduction

## The 4RF Aprisa SR Radio

The 4RF Aprisa SR is a point-to-multipoint digital radio providing secure narrowband wireless data connectivity for SCADA, infrastructure and telemetry applications.

The radios carry a combination of serial packet data and Ethernet data between the base station, repeater stations and remote stations.

The Aprisa SR is configurable as a point-to-multipoint base station, a remote station or a repeater station.



## Product Overview

### Network Coverage and Capacity

In a simple point-to-multipoint network, an Aprisa SR, configured as a base station, will communicate with multiple remote units in a given coverage area. With a link range of up to 60 km, a typical deployment will have 30 - 150 remote stations operating to the base station. However, geographic features, such as hills, mountains, trees and foliage, or other path obstructions, such as buildings, tend to limit radio coverage. Additionally, geography may reduce network capacity at the edge of the network where errors may occur and require retransmission. However, the Aprisa SR uses Forward Error Correction (FEC) which greatly improves the sensitivity performance of the radio resulting in less retries and minimal reduction in capacity.

Ultimately, the overall performance of any specific network will be defined by a range of factors including the geographic location, the number of remote stations in the base station coverage area and the traffic profile across the network. Effective network design will distribute the total number of remote stations across the available base stations to ensure optimal geographic coverage and network capacity.

The following are the maximum number of remotes that can operate to a base station for the product configuration:

Configuration	Maximum Number Of Remotes
Non Protected Base Station	500
Protected Base Station	150

### Remote Messaging

On start-up, the remote station transmits a registration message to the base stations which responds with a registration response. This allows the base station to record the details of all the remote stations active in the network.

If a remote station cannot register with the base station after multiple attempts (RF LED flashing red) within 10 minutes, it will automatically reboot. If a remote station has registered with the base station but then loses communication, it will automatically reboot within 6 minutes.

There are two message types in the Aprisa SR network, broadcast messages and unicast messages. Broadcast messages are transmitted by the base station to the remote stations and unicast messages are transmitted by the remote station to the base station.

All remotes within the coverage area will receive broadcast messages and pass them on to either the Ethernet or serial interface. The RTU determines if the message is intended for it and will accept it or discard it.

Only the base station can receive the unicast messages transmitted from the remote station. Unicast messages are ignored by other remote stations which may be able to receive them.

## Repeater Messaging

The Aprisa SR uses a routed protocol throughout the network whereby messages contain source and destination addresses. Upon registration, the radios populate an internal neighbor table to identify the radios in the network. The remote stations will register with a base station, or a repeater, and the repeater registers with a base station. In networks with a repeater, the repeater must register with the base station before the remotes can register with the repeater.

Additionally, all messages contain a 'message type' field in the header and messages are designated as either a 'broadcast' message, originating from a base station, or a 'unicast' message, originating from a remote station.

In a network with a repeater, or multiple repeaters, the base station broadcasts a message which contains a message type, a source address and a destination address. The repeater receives the message and recognizes it is a broadcast message, from the message type and source address and re-broadcasts the message across the network. All remote stations in the coverage area will receive the message but only the radio with the destination address will act upon the message.

Similarly, the remote station will send a unicast message which contains a message type (unicast) a source address and a destination address (the base station). The repeater will receive this message; recognize the message type and source address and forward it to the destination address.

It is this methodology which prevents repeater-repeater loops. If there is repeater (A) which, in some circumstances, is able to pick up the RF signal from another repeater (B), it will not forward the message as it will only forward broadcast messages from the base station (recognized by the source address). For unicast messages the repeater (A) will recognize that the message (from repeater (B)) is not from a remote with which it has an association and similarly ignore the message.

## Product Features

### Functions

- Point-to-Point (PTP) or Point-to-Multipoint (PMP) operation half duplex
- Licensed frequency bands:
  - VHF 136-174 MHz
  - UHF 400-470 MHz
- Channel sizes:
  - 12.5 kHz
  - 25 kHz
- Typical deployment of 30 remote stations from one base station with a practical limit of a few hundred remote stations
- Transparent to all common SCADA protocols; e.g. Modbus, IEC 60870-5-101/104, DNP3 or similar
- Dual antenna port option for external duplexers or filters (half duplex operation)
- Two Ethernet data interfaces *plus* two RS-232 asynchronous data interfaces
- Terminal server operation for transporting RS-232 traffic over IP
- Data encryption and authentication
- Layer 2 Ethernet and layer 3 IP filtering
- SNMPv2 and SNMPv3 support
- Radio and user interface redundancy (provided with Aprisa SR Protected Station)
- Complies with international standards, including ETSI RF, EMC, safety and environmental standards

### Performance

- Long distance operation
- High transmit power
- Low noise receiver
- Forward Error Correction
- Electronic tuning over the frequency band
- Thermal management for high power over a wide temperature range

### Usability

- Configuration / diagnostics via front panel Management Port USB interface, Ethernet interface
- Built-in webserver with full configuration, diagnostics and monitoring functionality, including remote station configuration / diagnostics over the radio link
- LED display for on-site diagnostics
- Software upgrade and diagnostic reporting via the Host Port USB flash drive
- Over-the-air software distribution and upgrades
- Date and Time Synchronization from an SNTP server
- Simple installation with integrated mounting holes for wall, DIN rail and rack shelf mounting

## Architecture

The Aprisa SR Architecture is based around a layered TCP/IP protocol stack:

- Physical
  - Proprietary wireless
  - Standard RS-232 and Ethernet
- Link
  - Proprietary wireless (channel access, ARQ, segmentation)
  - Standard Ethernet
- Network
  - Standard IP
  - Proprietary automatic radio routing table population algorithm
- Transport
  - Standard TCP, UDP
- Application
  - Proprietary management application software

## Security

The Aprisa SR provides security features to implement the key recommendations for industrial control systems. The security provided builds upon the best in class from multiple standards bodies, including:

- IEC/TR 62443 (TC65) 'Industrial Communications Networks - Network and System Security'
- IEC/TS 62351 (TC57) 'Power System Control and Associated Communications - Data and Communication Security'

The security features implemented are:

- Data encryption
  - Counter Mode Encryption (CTR) using Advanced Encryption Standard (AES)
- Data authentication
  - Cipher Block Chaining Message Authentication Code (CBC-MAC) using Advanced Encryption Standard (AES)
- Data payload security
  - CCM Counter with CBC-MAC integrity (NIST special publication 800-38C)
- Secured management interface protects configuration
- Address filtering enables traffic source authorization
- Proprietary physical layer protocol and modified MAC layer protocol based on standardized IEEE 802.15.4
- Licensed radio spectrum protects against interference

## Interfaces

### Antenna Interface

#### Single Antenna Option

- 1 x TNC, 50 ohm, female connector

#### Dual Antenna Port Option

- 2 x TNC, 50 ohm, female connectors

### Ethernet Interface

- 2 x ports 10/100 base-T Ethernet layer 2 switch using RJ45  
Used for Ethernet user traffic and product management.

### RS-232 Interface

- 1x RS-232 asynchronous port using RJ45 connector
- 1x RS-232 asynchronous port using USB host port with USB to RS-232 converter  
Used for RS-232 asynchronous user traffic only.

### USB Interfaces

- 1 x Management Port using USB micro type B connector  
Used for product configuration with the Command Line Interface (CLI).
- 1 x Host Port using USB standard type A connector  
Used for software upgrade and diagnostic reporting.

### Alarms

- 2 x hardware alarm inputs on the power and alarm connector  
The alarm states can be transported over the radio link and used to generate SNMP traps.



## Mounting

The Aprisa SR has four threaded holes (M4) in the enclosure base and two holes (5.2 mm) through the enclosure for mounting.

Mounting options include:

- DIN rail mounting with the Aprisa SR DIN Rail Mounting Bracket
- Rack shelf mounting
- Wall mounting
- Outdoor enclosure mounting

### DIN Rail Mounting

The Aprisa SR has an optional accessory part to enable the mounting on a standard DIN rail:

Part Number	Part Description
APSA-MBRK-DIN	4RF Aprisa SR Acc, Mounting, Bracket, DIN Rail

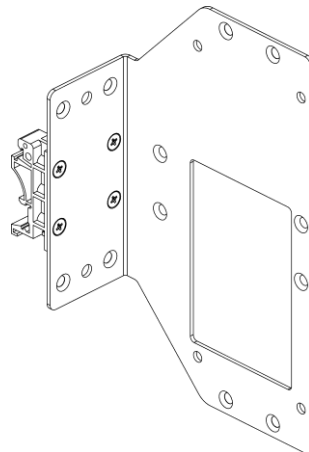

The Aprisa SR DIN rail mounting bracket can be mounted in four positions on a horizontal DIN rail:

- Vertical Mount (vertical enclosure perpendicular to the mount)
- Horizontal Mount (horizontal enclosure perpendicular to the mount)
- Flat Vertical Mount (vertical enclosure parallel to the mount)
- Flat Horizontal Mount (horizontal enclosure parallel to the mount)

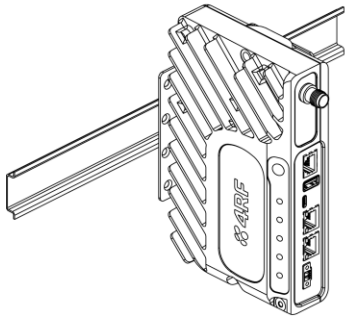

Vertical Mount

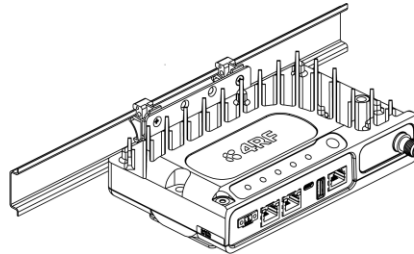

Horizontal Mount

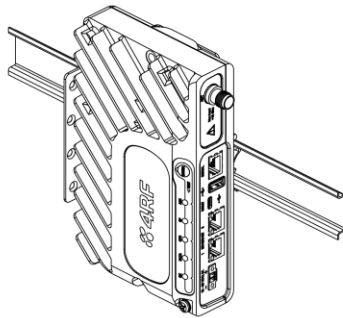

Flat Vertical Mount

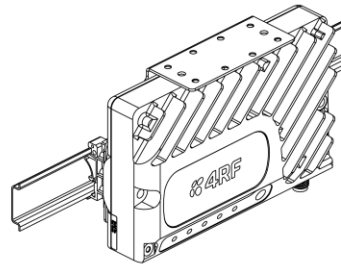

Flat Horizontal Mount

## Rack Shelf Mounting

The Aprisa SR can be mounted on a rack mount shelf using the four M4 threaded holes in the Aprisa SR enclosure base. The following picture shows Aprisa SR mounted on 1 RU rack mounted shelves.

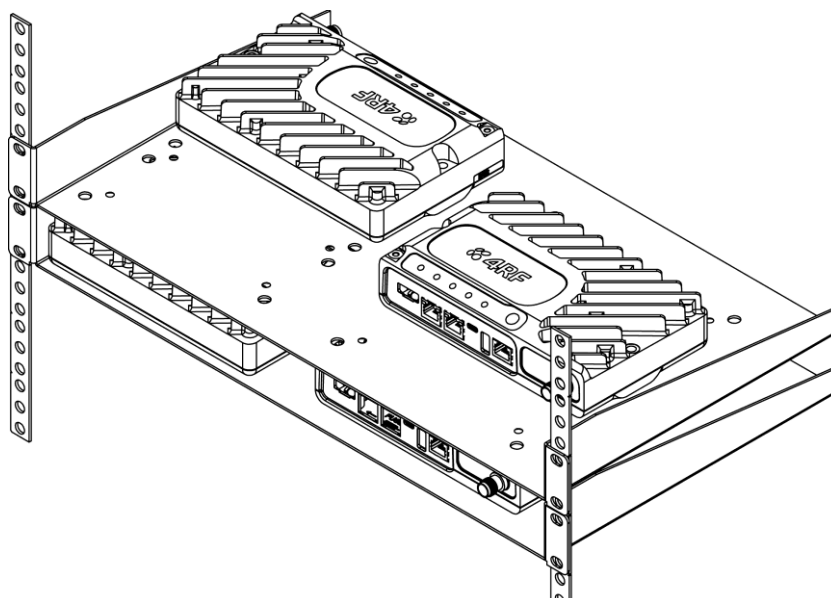

## Wall Mounting

The Aprisa SR can be mounted on a wall using the two holes through the enclosure (5.2 mm diameter). Typically, M5 screws longer than 35 mm would be used.

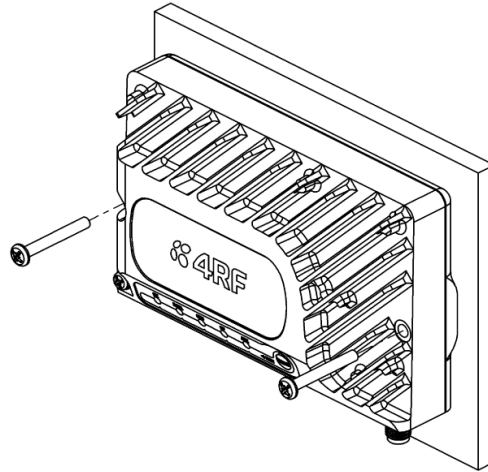

## Product Options

### Dual Antenna Port

The standard Aprisa SR uses a one or two frequency  $\frac{1}{2}$  duplex transmission mode which eliminates the need for a duplexer. However, a dual antenna port option is available for separate transmit and receive antenna connection to support external duplexers or filters. The transmission remains half duplex.



### Example Part:

Part Number	Part Description
APSR-N400-012- <u>DO</u> -12-ETAA	4RF SR, BR, 400-470 MHz, 12.5 kHz, DO, 12 VDC, ET, AA

## Protected Station

The Aprisa SR Protected Station provides radio and user interface protection for Aprisa SR radios when configured as a base station. The RF ports and interface ports from two standard Aprisa SR Radios are switched to the standby radio if there is a failure in the active radio.



### Example Part:

Part Number	Part Description
APSR-R400-012-SO-12-ETAA	4RF SR, PS, 400-470 MHz, 12.5 kHz, SO, 12 VDC, ET, AA

The Aprisa SR Protected Station is comprised of an Aprisa SR Protection Switch and two standard Aprisa SR radios. This configuration provides the ability to ‘hot-swap’ a failed radio without interrupting user traffic on the active radio. Additionally, retains the full temperature range specification of a single radio.

The Aprisa SR radios can be any of the currently available Aprisa SR radio frequency bands, channel sizes or single / dual antenna port options.

By default, the Aprisa SR Protected Station is configured with the left hand radio (A) designated as the primary radio and the right hand radio (B) designated as the secondary radio. Each radio is configured with its own unique IP and MAC address and the address of the partner radio.

On power-up, the primary radio will assume the active role and the secondary radio will assume the standby role. If, for some reason, only one radio is powered on it will automatically assume the active role.

## Operation

In normal operation, the active radio carries all RS-232 serial and Ethernet traffic over the radio link and the standby radio is unused with its transmitter turned off. Both radios are continually monitored for correct operation and alarms are raised if an event occurs.

Both the active and standby radios send regular ‘keep alive’ messages to each other to indicate if they are operating correctly. In the event of a failure on the active radio, the RF link and user interface traffic is automatically switched to the standby radio.

The failed radio can then be replaced in the field without interrupting user traffic (see ‘Aprisa SR User Manual 1.6.0’).

## Data Driven Protected Station

The Aprisa SR Data Driven Protected Station provides radio and RS-232 serial port user interface protection for Aprisa SR radios when configured as a base station.



### Example Part:

Part Number	Part Description
APSR-D400-012-DO-12-ETAA	4RF SR, PD, 400-470 MHz, 12.5 kHz, DO, 12 VDC, ET, AA

The Aprisa SR Data Driven Protected Station shown is comprised of two standard Aprisa SR dual antenna port option radios and two external duplexers mounted on 19" rack mounting shelves (as shown above).

The Aprisa SR radios can be any of the currently available Aprisa SR radio frequency bands, channel sizes or single / dual antenna port options.

By default, the Aprisa SR Data Driven Protected Station is configured with the left hand radio (A) designated as the primary radio and the right hand radio (B) designated as the secondary radio.

Each radio is configured with its own unique IP and MAC address and the address of the partner radio.

On power-up, the primary radio will assume the active role and the secondary radio will assume the standby role. If, for some reason, only one radio is powered on it will automatically assume the active role.

## Operation

In normal operation, the active radio carries all RS-232 serial and Ethernet traffic over the radio link and the standby radio is unused with its transmitter turned off. Both radios are continually monitored for correct operation and alarms are raised if an event occurs.

Both the active and standby radios send regular 'keep alive' messages to each other to indicate if they are operating correctly. In the event of a failure on the active radio, the RF link and user interface traffic is automatically switched to the standby radio.

The failed radio can then be replaced in the field without interrupting user traffic.

## Switch Over

The switch over to the standby radio can be initiated automatically, on fault detection, or manually via the Hardware Manual Lock switch on the Protection Switch or the Software Manual Lock from SuperVisor.

Additionally, it is possible to switch over the radios remotely without visiting the station site, via the remote control connector on the front of the Protection Switch.

## Configuration Management

The Primary and Secondary radios are managed with the embedded web-based management tool, SuperVisor, by using either the Primary or Secondary IP address. Configuration changes in one of the radios will automatically be reflected in the partner radio.

To ensure all remote stations are registered to the correct (active) base station, changes to the Network Table are automatically synchronized from the active radio to the standby radio. The Network Table is only visible on the active radio. This synchronization does not occur if the Hardware Manual Lock is active

## Installation

### Mounting

The Aprisa SR Data Driven Protected Station is designed to mount in a standard 19" rack on two 1U rack mounting shelves.

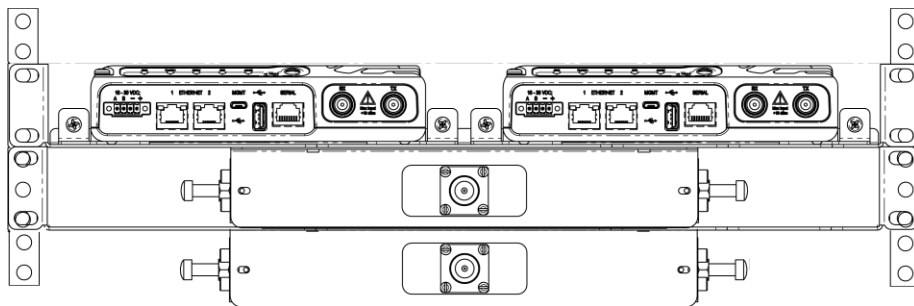
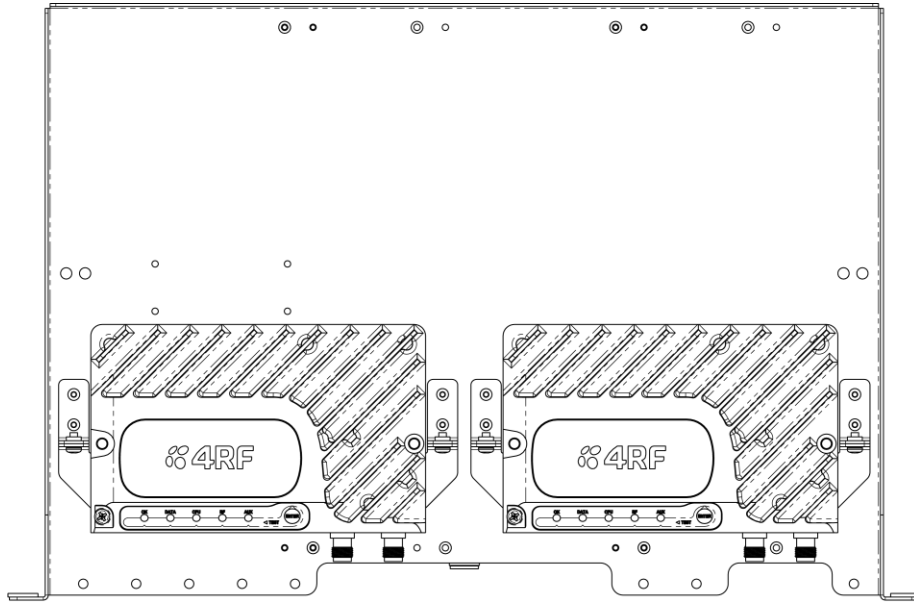



## Cabling

The Aprisa SR Data Driven Protected Station is delivered with the radios, duplexers, rack mounting shelves and RF cables.



---

Note: The picture demonstrates the RF cabling but the product is delivered with the cables separately packaged.

---

The set of interconnect cables is available as a spare part.

## Power

A +10.5 to +30 V DC external power source must be connected to both the A and B Phoenix Contact 4 pin male power connectors. The maximum combined power consumption is 35 Watts.

## Duplexer Kits

The Aprisa SR product range contains Duplexer Kit accessories for use with the Dual Antenna port Aprisa SR radios.

### UHF Duplexer Kits

The Aprisa SR UHF Duplexer Kit contains:

- 1x 1U 19" rack mount shelf with duplexer mounting brackets and screws
- 1x Duplexer
- 2x TNC to SMA right angle 590mm cables



#### Part Number

APSA-KDUP-400-B1

#### Part Number

4RF SR Acc, Kit, Duplexer, 400-470 MHz, s 5 MHz, p 0.5 MHz, ext

### VHF Duplexer Kits

The Aprisa SR VHF Duplexer Kit contains:

- 1x 1U 19" rack mount shelf with duplexer mounting brackets and screws
- 1xVHF Procom Duplexer
- 1x VHF Filter, Procom BPF 2/3 HX-150, 145 to 174 MHz
- 1x N type male to N type male 325mm
- 2x TNC to N type male right angle 590mm cable



#### Part Number

APSA-KDUP-VHF-R2

APSA-KDUP-VHF-R3

APSA-KDUP-VHF-R4

APSA-KDUP-VHF-R5

APSA-KDUP-VHF-R6

APSA-KDUP-VHF-R7

#### Part Number

4RF SR Acc, Kit, Duplexer, 152-175 MHz, s4-6 MHz, p100 kHz, High

4RF SR Acc, Kit, Duplexer, 152-175 MHz, s6-8 MHz, p100 kHz, High

4RF SR Acc, Kit, Duplexer, 152-175 MHz, s8-10 MHz, p100 kHz, High

4RF SR Acc, Kit, Duplexer, 138-156 MHz, s4-6 MHz, p100 kHz, Low

4RF SR Acc, Kit, Duplexer, 138-156 MHz, s6-8 MHz, p100 kHz, Low

4RF SR Acc, Kit, Duplexer, 138-156 MHz, s8-10 MHz, p100 kHz, Low

## 2. Specifications

### RF Specifications

#### Frequency Bands

Broadcast Band	Frequency Band	Frequency Tuning Range	Synthesizer Step Size
VHF	136 MHz	136-174 MHz	3.125 kHz
UHF	400 MHz	400-470 MHz	6.250 kHz

#### Channel Sizes

Channel Size	Gross Radio Capacity
12.5 kHz	9.6 kbit/s
25 kHz	19.2 kbit/s

#### Transmitter

Transmit Power output	0.01 to 5.0 W (+10 to +37 dBm, in 1 dB steps)
Adjacent channel power	< -60 dBc
Transient adjacent channel power	< -50 dBc
Spurious emissions	< -37 dBm
Attack time	< 1.5 ms
Release time	< 1.5 ms
Data turnaround time	< 10 ms
Frequency stability	± 1 ppm
Frequency aging	< 1 ppm / annum
Synthesizer lock time	< 1.5 ms (5 MHz step)

---

**Note:** The Aprisa SR transmitter contains power amplifier protection which allows the antenna to be disconnected from the antenna port without product damage.

---

## Receiver

		12.5 kHz	25 kHz
Receiver sensitivity	BER < 10 <sup>-2</sup>	-117 dBm	-114 dBm
	BER < 10 <sup>-3</sup>	-115 dBm	-112 dBm
	BER < 10 <sup>-6</sup>	-113 dBm	-110 dBm
Adjacent channel selectivity		-47 dBm	-37 dBm
Co-channel rejection		> -12 dB	

Intermodulation response rejection	-37 dBm
Blocking or desensitization	-17 dBm
Spurious response rejection	-32 dBm

## Modem

Modulation	4-CPFSK
Forward Error Correction	¾ trellis code

## Data Payload Security

Data payload security	CCM* Counter with CBC-MAC
Data encryption	Counter Mode Encryption (CTR) using Advanced Encryption Standard (AES) 128, 192 or 256 bit
Data authentication	Cipher Block Chaining Message Authentication Code (CBC-MAC) using Advanced Encryption Standard (AES) 128, 192 or 256 bit

# Interface Specifications

## Ethernet Interface

The Aprisa SR radio features an integrated 10Base-T/100Base-TX layer-2 Ethernet switch.

To simplify network setup, each port supports auto-negotiation and auto-sensing MDI/MDIX. Operators can select from the following preset modes:

- Auto negotiate
- 10Base-T half or full duplex
- 100Base-TX half or full duplex

The switch is IEEE 802.3-compatible. It passes VLAN tagged traffic.

<b>General</b>	Interface	RJ-45 x 2 (Integrated 2-port switch)
	Cabling	CAT-5 UTP, supports auto MDIX (Standard Ethernet)
	Maximum line length	100 metres on cat-5 or better
	Bandwidth allocation	The Ethernet capacity maximum is determined by the available radio link capacity.
	Maximum transmission unit	Option setting of 1522 or 1536 octets
	Address table size	1024 MAC addresses
	Ethernet mode	10Base-T or 100Base-TX Full duplex or half duplex (Auto-negotiating and auto-sensing)
<b>Diagnostics</b>	Left Green LED	Off: no Ethernet signal received On: Ethernet signal received
	Right Green LED	Off: Indicates no data traffic present on the interface Flashing: Indicates data traffic present on the interface

## RS-232 Asynchronous Interface

The Aprisa SR radio's ITU-T V.24 compliant RS-232 interface is configured as a Cisco® pinout DCE. The interface terminates to a DTE using a straight-through cable or to a DCE with a crossover cable (null modem).

The interface uses two handshaking control lines between the DTE and the DCE.

<b>General</b>	Interface	ITU-T V.24 / EIA/TIA RS-232E
	Interface direction	DCE only
	Maximum line length	10 metres
<b>Async parameters</b>	Standard mode data bits	7 or 8 bits
	Standard mode parity	Configurable for None, Even or Odd
	Standard mode stop bits	1 or 2 bits
	Interface baud rates	300, 1200, 2400, 4800, 9600, 19200, 38400, 57600 and 115200 bit/s
<b>Control signals</b>	DCE to DTE	CTS, RTS, DSR, DTR

## Hardware Alarms Interface

The power and alarm connector provides two hardware alarm contacts for alarm transmission to the other radios in the network.

Alarm input	Logic 4700 ohms pullup to +3.3 VDC
-------------	------------------------------------

## Protection Switch Specifications

RF Insertion Loss	< 0.5 dB
Remote Control inputs	Logic 4700 ohms pullup to +3.3 VDC

## Power Specifications

### Power Supply

#### Aprisa SR Radio

Nominal voltage	+13.8 VDC (negative earth)
Input voltage range	+10 to +30 VDC
Maximum power input	30 W
Connector	Phoenix Contact 4 pin male screw fitting MC 1.5/ 4-GF-3.5

#### Aprisa SR Protected Station

Nominal voltage	+13.8 VDC (negative earth)
Input voltage range	+10 to +30 VDC
Maximum power input	35 W
Connector	2x Phoenix Contact 2 pin male screw fitting MC 1.5/ 2-GF-3.5

#### Aprisa SR Data Driven Protected Station

Nominal voltage	+13.8 VDC (negative earth)
Input voltage range	+10 to +30 VDC
Maximum power input	35 W
Connector	2x Phoenix Contact 4 pin male screw fitting MC 1.5/ 2-GF-3.5

### Power Consumption

#### Aprisa SR Radio

Mode	Power Consumption
Transmit / Receive	< 22.5 W for 5W transmit power
	< 15.0 W for 1W transmit power
Receive only	< 6 W full Ethernet traffic activity
	< 4.5 W no Ethernet traffic activity

#### Aprisa SR Protected Station and Aprisa SR Data Driven Protected Station

Mode	Power Consumption
Transmit / Receive	< 31 W for 5W transmit power
	< 23.5 W for 1W transmit power
Receive only	< 14.5 W full Ethernet traffic activity
	< 11.5 W no Ethernet traffic activity

## Power Dissipation

### Aprisa SR Radio

Transmit Power	Power Dissipation
1W transmit power	< 14.0 W
5W transmit power	< 17.5 W

### Aprisa SR Protected Station and Aprisa SR Data Driven Protected Station

Transmit Power	Power Dissipation
1W transmit power	< 22.5 W
5W transmit power	< 26.0 W



## General Specifications

### Environmental

Operating temperature range	-40 to +70° C
Storage temperature range	-40 to +80° C
Operating humidity	Maximum 95% non-condensing
Acoustic noise emission	No audible noise emission

### Mechanical

#### Aprisa SR Radio

Dimensions	Width 177 mm Depth 110 mm (126 mm with TNC connector) Height 41.5 mm
Weight	720 g
Colour	Matt black
Mounting	Wall (2 x M5 screws) Rack shelf (2 x M4 screws) DIN rail bracket

#### Aprisa SR Protected Station

Dimensions	Width 430 mm Depth 220 mm (incl interconnect cables) Height 90 mm
Weight	4.46 kg
Colour	Matt black
Mounting	Rack mount (2 x M4 screws)

### Compliance

	12.5 kHz	25 kHz
Radio	EN 300 113-2	EN 302 561
EMI / EMC	EN 301 489 Parts 1 & 5	
Safety	EN 60950-1:2006	
Environmental	ETS 300 019 Class 3.4	



## 3. Management

### SuperVisor

The Aprisa SR contains an embedded web server application (SuperVisor) to enable element management with any major web browser (such as Mozilla Firefox or Microsoft® Internet Explorer).

SuperVisor enables operators to configure and manage the Aprisa SR base station radio and repeater / remote station radios over the radio link.

The key features of SuperVisor are:

- Full element management, configuration and diagnostics
- Manage the entire network from the Base Station (remote management of elements)
- Managed network software distribution and upgrades
- Performance and alarm monitoring of the entire network, including RSSI, alarm states, time-stamped events, etc.
- View and set standard radio configuration parameters including frequencies, transmit power, channel access, serial, Ethernet port settings
- Set and view security parameters
- User management

The following are four examples of SuperVisor screens:

## Viewing the Aprisa SR Terminal Summary

## Configuring the Aprisa SR Terminal Device

## Configuring the Aprisa SR Radio Channel Setup

**4RF SUPERVISOR** **Aprisa SR**

Base Station OK DATA CPU RF AUX Network  
Status

Terminal **Radio** Serial Ethernet Networking Security Maintenance Events Software

Radio Summary Channel Summary Radio Setup **Channel Setup**

**CHANNEL SETTINGS**

Access Scheme

Packet Size (bytes)

Packet Time-to-live (ms)

Packet Filtering

Serial Data Stream Mode

**TRAFFIC SETTINGS**

Serial Data Priority

Ethernet Data Priority

Management Data Priority

Background Bulk Data Transfer Rate

**DATA COMPRESSION**

IP Header Compression Ratio

Ready Radio: Base Station [Logout ADMIN](#)

## Configuring the Aprisa SR Radio Setup

**4RF SUPERVISOR** **Aprisa SR**

Base Station OK DATA CPU RF AUX Network  
Status

Terminal **Radio** Serial Ethernet Networking Security Maintenance Events Software

Radio Summary Channel Summary **Radio Setup** Channel Setup

**TRANSMITTER**

TX Frequency (MHz)  (400 to 470 MHz, in 6.25 kHz steps)

TX Power (dBm)  (10 to 37 dBm, in 1 dB steps)

**RECEIVER**

RX Frequency (MHz)  (400 to 470 MHz, in 6.25 kHz steps)

Ready Radio: Base Station [Logout ADMIN](#)

## Command Line Interface

The Aprisa SR has a Command Line Interface (CLI) which provides basic product setup and configuration. This interface can be accessed via an Ethernet Port (RJ-45) or the Management Port (USB micro type B).

```
MPA >>cd APRISASR-MIB-4RF
```

```
MPA APRISASR-MIB-4RF >>ls Terminal
```

```
MPA APRISASR-MIB-4RF >>ls Terminal
+-----+
|S.NO|ATTRIBUTE NAME                |ATTRIBUTE VALUE
+-----+
|1   |termName                      |Base Station
|2   |termLocation                  |Wellington
|3   |termContactName               |4RF Communications Ltd
|4   |termContactDetails            |support@4rf.com
|5   |termTimeFormat                |time24h (1)
|6   |termDateFormat                |ddmmyyyy (1)
|7   |termDateTime                  |2011-1-1,15:21:21.0
|8   |termEthController1IpAddress   |172.17.10.2
|9   |termEthController1SubnetMask  |255.255.0.0
|10  |termEthController1Gateway     |0.0.0.0
|11  |termRfNwkPanId                |CAFE
|12  |termRfNwkRadius               |1
|13  |termInbandManagementEnabled  |true (1)
|14  |termInbandManagementTimeoutSec|10
+-----+

MPA APRISASR-MIB-4RF >>
```

## LED Display Panel

The Aprisa SR has an LED Display panel which provides on-site alarms / diagnostics without the need for PC.

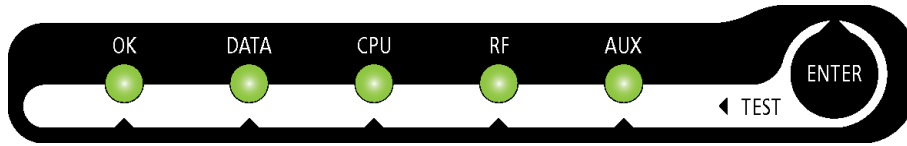

### Normal Operation

In normal radio operation, the LEDs indicate the following conditions:

	OK	DATA	CPU	RF	AUX
<b>Solid Red</b>	Alarm present with severity Critical, Major and Minor			<i>RF path fail</i>	
<b>Flashing Red</b>				<i>Radio not connected to a base station</i>	
<b>Solid Orange</b>	Alarm present with Warning Severity		<i>Standby radio in Protected Station</i>		
<b>Flashing Orange</b>		<i>Tx Data or Rx Data on the USB management or data port</i>	<i>Device detect on the USB host port</i>	<i>RF path TX is active</i>	<i>Diagnostics Function Active</i>
<b>Flashing Green</b>		<i>Tx Data or Rx Data on the serial port</i>		<i>RF path RX is active</i>	
<b>Solid Green</b>	<i>Power on and functions OK and no alarms</i>	<i>All interface ports are OK</i>	<i>Processor Block is OK and Active radio in Protected Station</i>	<i>RF path is OK</i>	

LED Colour	Severity
Green	No alarm - information only
Orange	Warning alarm
Red	Critical, major or minor alarm

## Single Radio Software Upgrade

During a radio software upgrade, the LEDs indicate the following conditions:

- Software upgrade started - the OK LED flashes orange
- Software upgrade progress indicated by running AUX to DATA LEDs
- Software upgrade completed successfully - the OK LED solid orange
- Software upgrade failed - any LED flashing red during the upgrade

## Network Software Upgrade

During a network software upgrade, the AUX LED flashes orange on the base station and all remote stations.

## Test Mode

In Test Mode, the LED Display panel presents a real time visual display of the RSSI. This can be used to adjust the antenna for optimum signal strength.

OK LED	DATA LED	CPU LED	RF LED	AUX LED	RSSI
●	●	●	●	●	$\geq -80$ dBm
●	●	●	●	○	-84 dBm to -81 dBm
●	●	●	○	○	-88 dBm to -85 dBm
●	●	○	○	○	-92 dBm to -89 dBm
●	○	○	○	○	-96 dBm to -93 dBm
●	●	●	●	●	-100 dBm to -97 dBm
●	●	●	●	○	-104 dBm to -101 dBm
●	●	●	○	○	-108 dBm to -105 dBm
●	●	○	○	○	-112 dBm to -109 dBm
●	○	○	○	○	-116 dBm to -113 dBm
●	●	●	●	●	< RSSI threshold
●	●	●	●	●	No response received



## 4. Applications

This section describes sample Aprisa SR radio applications.

The following applications are described:

- Basic point-to-multipoint application
- Advanced point-to-multipoint application with repeaters
- Multi-interface point-to-multipoint application

### Basic point-to-multipoint application

Single base station with Ethernet SCADA data inputs to multiple geographically remote sites with Ethernet RTUs requiring control and data acquisition.

The base station receives Ethernet frames from the SCADA server LAN and broadcasts all Ethernet frames to all remote stations

Each remote site receives Ethernet frames from the RTU and unicasts over the air to the base station.

The base station uses an omni directional antenna to provide wide coverage and the remote stations are fitted with directional Yagi antennas to provide higher gain.

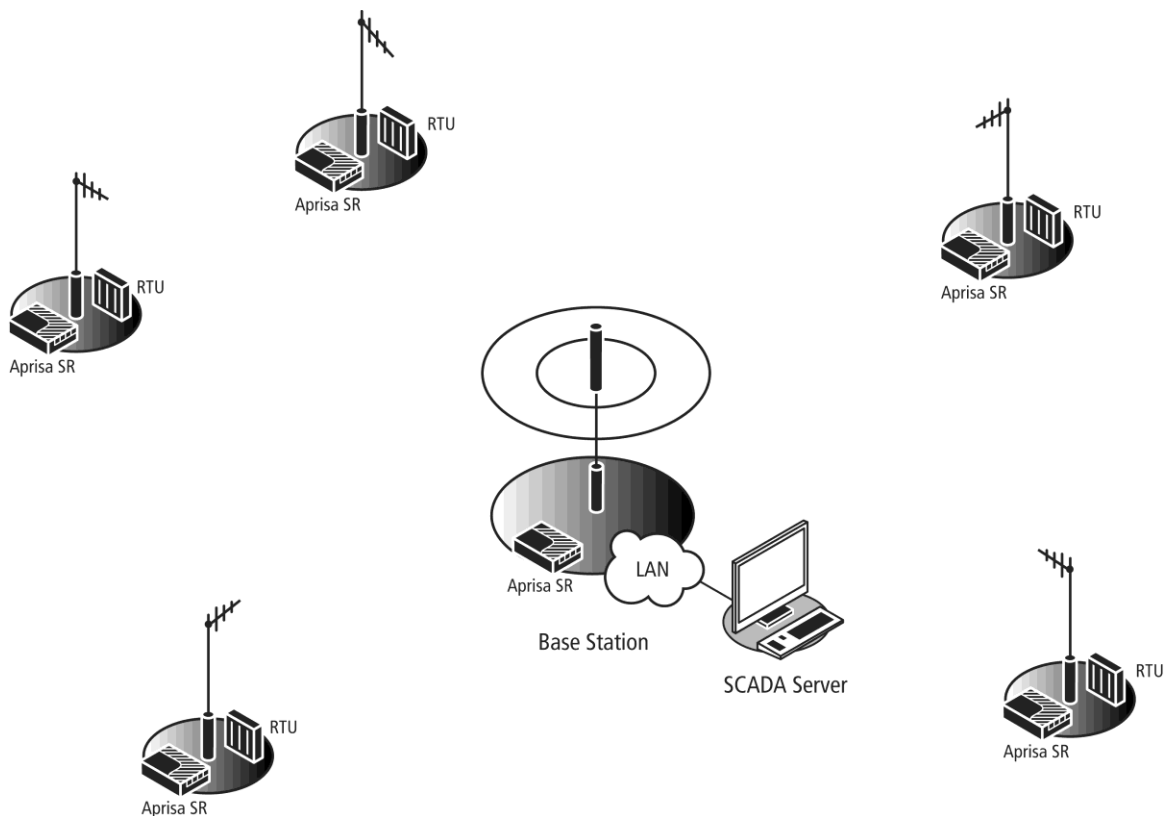

## Advanced point-to-multipoint application with repeater

Single base station with Ethernet SCADA data inputs to multiple geographically remote sites with Ethernet RTUs requiring control and data acquisition. A repeater is deployed to service remote sites beyond the reach of the base station.

The base station receives Ethernet frames from the SCADA server LAN and broadcasts all Ethernet frames to the repeater and its remote stations.

Three remote sites have direct radio communication with the base station but the other two remote sites operate via the repeater site.

Each remote site receives Ethernet frames from the RTU and unicasts over the air to the repeater / base station.

The base station and the repeater station use an omni directional antenna to provide wide coverage and the remote stations are fitted with directional Yagi antennas to provide higher gain.

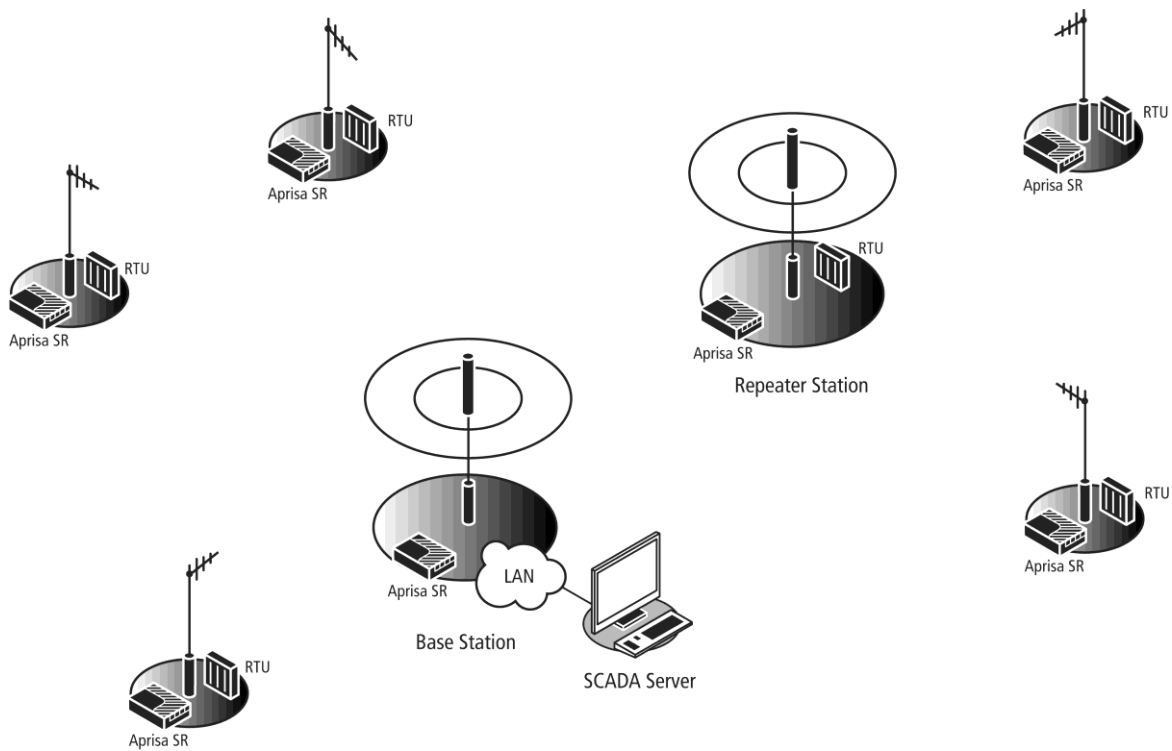

## Multi-interface point-to-multipoint application

Single base station with Ethernet and RS-232 SCADA data inputs to multiple geographically remote sites with Ethernet and RS-232 RTUs requiring control and data acquisition.

The base station receives Ethernet / RS-232 frames from the SCADA servers and broadcasts all frames to all remote stations

Each remote site receives Ethernet / RS-232 frames from the RTU and unicasts over the air to the base station.

The base station uses an omni directional antenna to provide wide coverage and the remote stations are fitted with directional Yagi antennas to provide higher gain.

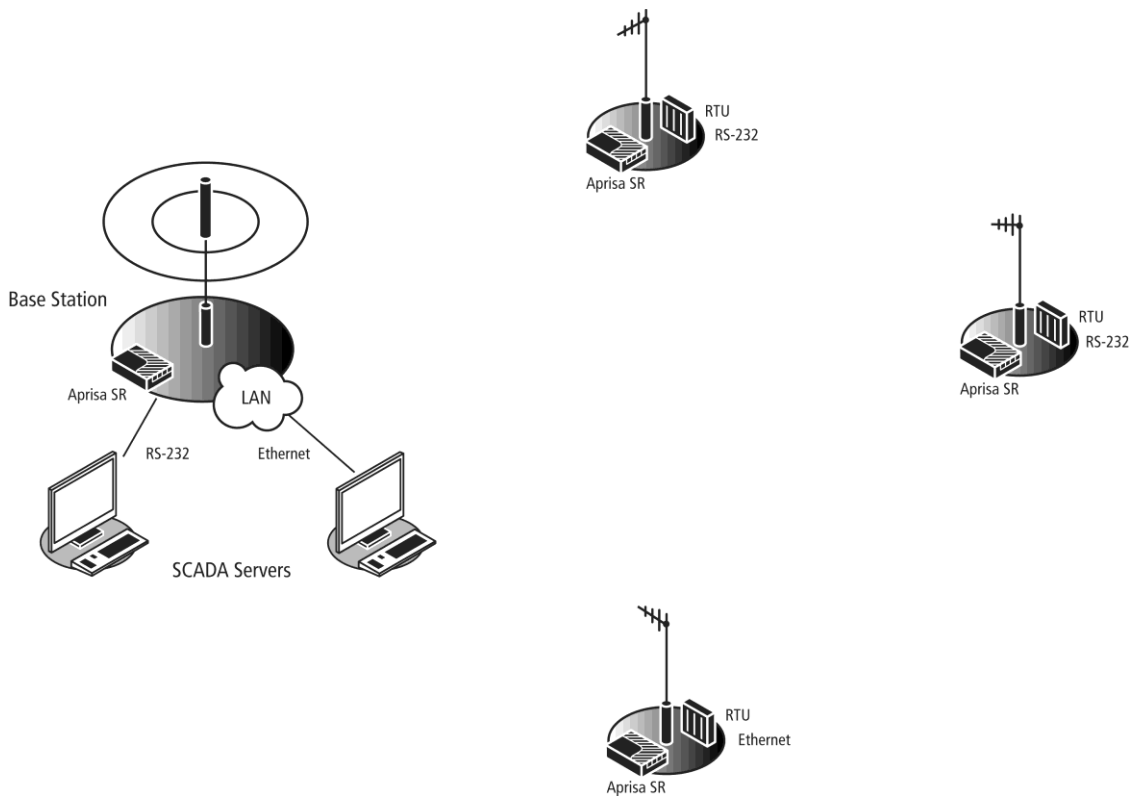

## 5. Architecture

### Product Description

There are three components to the wireless interface: the Physical Layer (PHY), the Data Link Layer (DLL) and the Network Layer. These three layers are required to transport data across the wireless channel in the Point-to-Multipoint (PMP) configuration. The Aprisa SR DLL is largely based on the 802.15.4 MAC layer using a proprietary implementation.

#### Physical Layer

The Aprisa SR PHY uses a one or two frequency  $\frac{1}{2}$  duplex transmission mode which eliminates the need for a duplexer. However, a Dual Antenna port option is available for separate transmit and receive antenna connection to support external duplexers or filters (half duplex operation).

Remote nodes are predominantly in receive mode with only sporadic bursts of transmit data. This reduces power consumption.

The Aprisa SR is a packet based radio. Data is sent over the wireless channel in discrete packets / frames, separated in time. The PHY demodulates data within these packets with coherent detection.

The Aprisa SR PHY provides carrier, symbol and frame synchronisation predominantly through the use of preambles. This preamble prefixes all packets sent over the wireless channel which enables fast synchronisation.

#### Data Link Layer / MAC layer

The Aprisa SR PHY enables multiple users to be able to share a single wireless channel; however a DLL is required to manage data transport. The two key components to the DLL are channel access and hop by hop transmission.

#### Channel Access

The Aprisa SR radio has two modes of channel access, Access Request and Listen Before Send.

Access Mode	Function
Access Request	Channel access scheme where the base stations controls the communication on the channel. Remotes ask for access to the channel, and the base station grants access if the channel is not occupied.
Listen Before Send	Channel access scheme where network elements listen to ensure the channel is clear, before trying to access the channel.

## Access Request

This scheme is particularly suited to digital SCADA systems where all data flows through the base station. In this case it is important that the base station has contention-free access as it is involved in every transaction. The channel access scheme assigns the base station as the channel access arbitrator and therefore inherently it has contention-free access to the channel. This means that there is no possibility of contention on data originating from the base station. As all data flows to or from the base station, this significantly improves the robustness of the system.

All data messages are controlled via the AG (access grant) control message and therefore there is no possibility of contention on the actual end user data. If a remote station accesses the channel, the only contention risk is on the AR (access request) control message. These control messages are designed to be as short as possible and therefore the risk of collision of these control messages is significantly reduced. Should collisions occur these are resolved using a random back off and retry mechanism.

As the base station controls all data transactions multiple applications can be effectively handled, including a mixture of polling and report by exception.

## Listen Before Send

The Listen Before Send channel access scheme is realized using Carrier Sense Multiple Access (CSMA). In this mode, a pending transmission requires the channel to be clear. This is determined by monitoring the channel for other signals for a set time prior to transmission. This results in reduced collisions and improved channel capacity.

There are still possibilities for collisions with this technique e.g. if two radios simultaneously determine the channel is clear and transmit at the same time. In this case an acknowledged transaction may be used. The transmitter requests an ACK to ensure that the transmission has been successful. If the transmitter does not receive an ACK, then random backoffs are used to reschedule the next transmission.

## Hop by Hop Transmission

Hop by Hop Transmission is realized in the Aprisa SR by adding a MAC address header to the packet. For 802.15.4, there are 2 addresses, the source and destination addresses.

## Network Layer

### Packet Routing

Packet routing is realized in the Aprisa SR by adding a network address header to the packet. This contains source and destination addresses. For the Network Layer, there are 2 addresses, the address of the originating radio and the address of the terminating radio (i.e. end to end network). This is required for routing packets across multiple hops e.g. PMP with repeaters.

The Aprisa SR uses an automated method for performing address assignment and routing information.

There are two types of packets: unicast and broadcast. Only the base station sends broadcasts which are received by all remote stations. User packets are not interpreted as the radio link is transparent.

### Traffic

- Data originating on the base station is broadcast to all repeater stations and remote stations
- Data originating on a remote station is unicast to the base station only  
This can be via multiple repeater stations.
- Data originating on a repeater station is unicast to the base station only
- Data originating on a base station serial port is terminated on remote station serial ports only
- Data originating on a base station Ethernet port is terminated on remote station Ethernet ports or serial ports (Terminal Server mode)

### User Traffic

User traffic is prioritized depending on the Serial and Ethernet Data Priority options.

If the Serial and Ethernet Data Priority options are equal, then first come first served is invoked.

Repeater stations repeat traffic also on a first come first served basis.

### Management Traffic

Ethernet Management Traffic is also prioritized relative to user traffic.

## Security

The Aprisa SR provides security features to implement the key recommendations for industrial control systems. The security provided builds upon the best in class from multiple standards bodies, including:

- IEC/TR 62443 (TC65) 'Industrial Communications Networks - Network and System Security'
- IEC/TS 62351 (TC57) 'Power System Control and Associated Communications - Data and Communication Security'

The security features implemented are:

- Data encryption
  - Counter Mode Encryption (CTR) using Advanced Encryption Standard (AES)
- Data authentication
  - Cipher Block Chaining Message Authentication Code (CBC-MAC) using Advanced Encryption Standard (AES)
- Data payload security
  - CCM Counter with CBC-MAC integrity (NIST special publication 800-38C)
- Secured management interface protects configuration
- Address filtering enables traffic source authorization
- Proprietary physical layer protocol and modified MAC layer protocol based on standardized IEEE 802.15.4
- Licensed radio spectrum protects against interference

## Product Architecture

The following are the key components of the Aprisa SR design:

### High performance $\Sigma\Delta$ fractional-N synthesizer

- 2x output frequency VCO for minimal pulling during transmit
- Wideband design electronically tunes over entire band
- Tx and Rx LO operate on the same frequency, reducing the tuning range of the VCO and therefore better noise performance
- Proven ultra low noise technology - 50dB SNR easily achieved

### Direct IQ modulation

- Simple IQ modulation line up reduces part count and improves MTBF
- No mixing stages so no spurious responses present at the transmitter output

### Tx turn-on time limited primarily by PA ramping

- Robust, closed-loop power control - fast, accurate power ramp up and down

### MOSFET PA device

- High efficiency (>60% PAE at 8W)
- Very low thermal resistance (2.5°C/W)

### Direct IQ down-conversion

- Excellent Intermodulation distortion characteristics as channel filter can be placed directly after the mixer without impacting noise figure
- High Q active channel filtering helps achieve selectivity performance
- Low parts count and no crystal filters help to keep receiver performance extremely stable over temperature

### Integrated heat sink

- Limits number of mechanical interfaces
- Fin design optimized for natural convection

### Monitoring and software control

- Temperature control loop shuts down transmitter when the temperature exceeds continuous operation at 70°C
- Monitoring of RSSI and PA current help to make sure the RF hardware is functioning to specification



## Radio Block Diagram

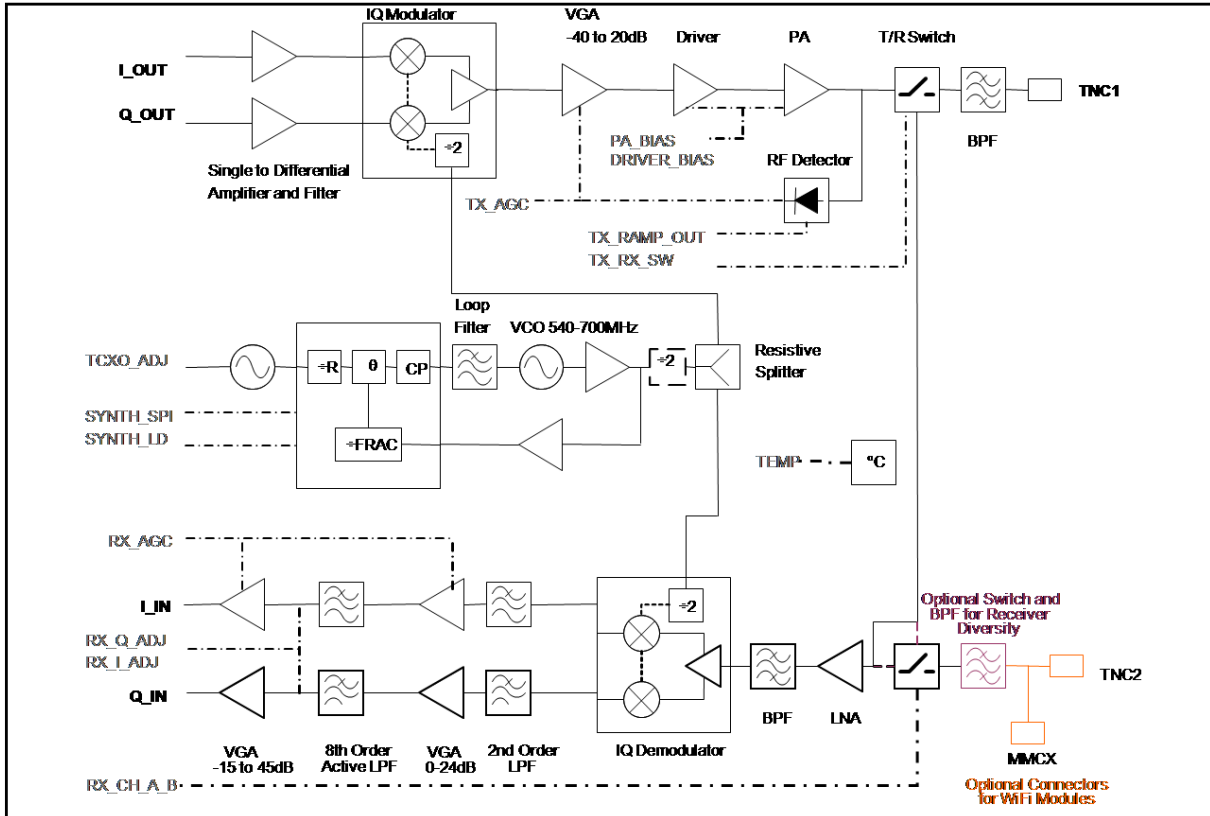

## Modem Block Diagram

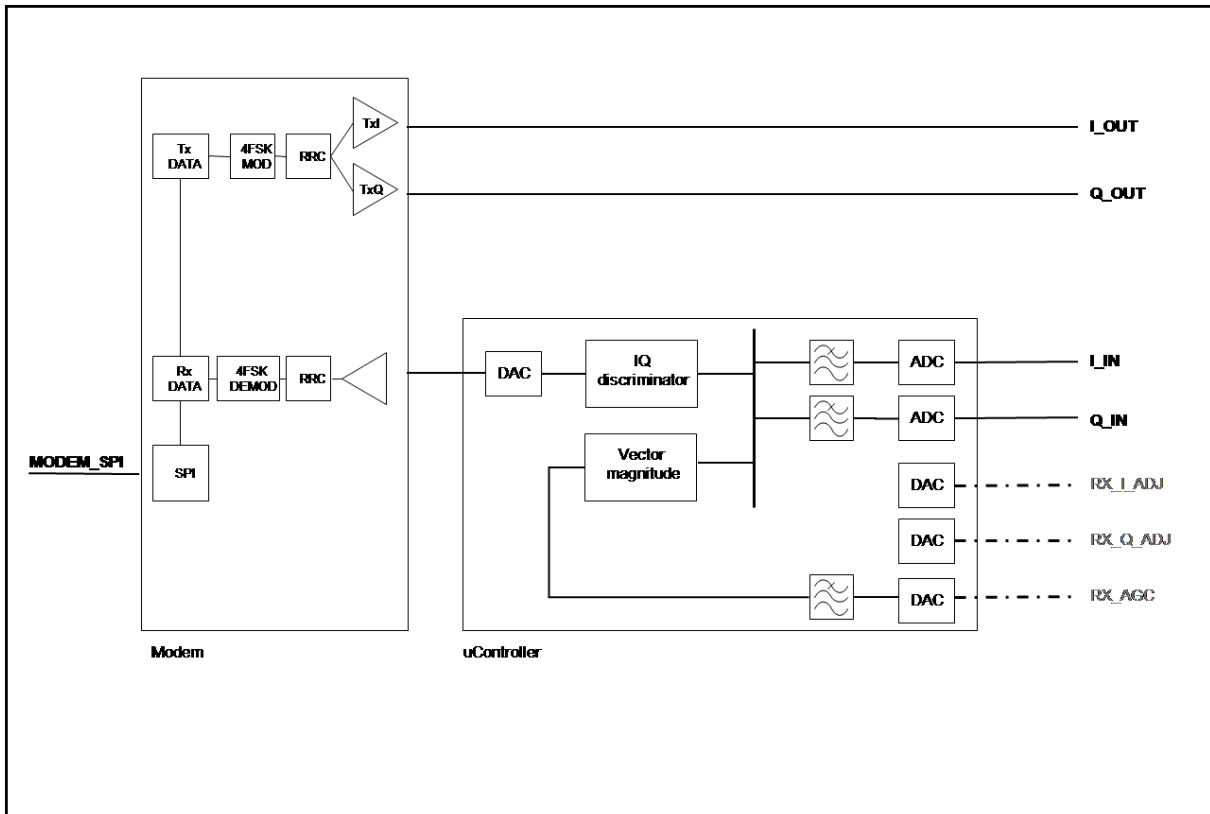

## 6. Contact Us

For further information or assistance, please contact Customer Support or your local 4RF representative.

Our area representative contact details are available from our website:

4RF Limited

26 Glover Street, Ngauranga

PO Box 13-506

Wellington 6032

New Zealand

E-mail [support@4rf.com](mailto:support@4rf.com)

Web site [www.4rf.com](http://www.4rf.com)

Telephone +64 4 499 6000

Facsimile +64 4 473 4447

Attention Customer Services